

Wall console ready for connection

without screw-in heater

To maximise PV own power consumption

- for **ASKOHEAT+** screw-in heater
- 7 levels up to 5.2kW
- for high storage temperatures up to 85°C
- excellent legionella protection

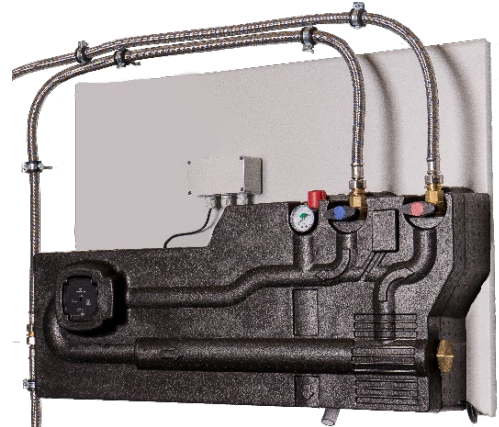

Application

For external connection on heating buffer tank

1. For storage of PV energy as heat in heating water
2. As emergency heating for heating systems
3. For high storage temperatures for legionella protection (hygienic storage)
4. For existing buffer tanks without heating element access

Features

This wall console can be retrofitted easily and individually and will be connected to the on-site buffer tank or integrated in the intake and outlet of the heating lines.

Increasing the storage temperature can contribute to legionella protection in a hygienic storage. A temperature between 50 and 75°C can be set manually on the thermostatic valve.

Thanks to the circulation pump in the **ASKOWALL+**, the water circulates until the set temperature is reached. As soon as this set temperature is reached, the valve opens and the hot medium is stratified in the storage tank. If the temperature in the **ASKOWALL+** falls below the set value due to cold water flowing in, the valve closes.

7-stage **ASKOHEAT+** screw-in heater with 1½" thread can be used up to a maximum immersion length of 750mm.

Order summary

Type	Order no.	Additional text	Immersion length [EL]
ASKOWALL+	012-2103	1.75 kW up to 5.2 kW	up to max. 750mm
ASKOHEAT+			
AHIR-BI-plus-1.75	012-6391	7x0.25kW	400mm
AHIR-BI-plus-3.5	012-6932	7x0.50kW	600mm
AHIR-BI-plus-4.4	012-6393	7x0.65kW	700mm
AHIR-BI-plus-5.2	012-6934	7x0.75kW	750mm
Connection hoses for ASKOWALL & ASKOWALL+	012-0130	1600mm length	
Probe set with 4 probes for ASKOHEAT+	012-0126	5m cable length	
ASKOSET+ Energy meter, energy manager & power pack	012-2280		

Accessories

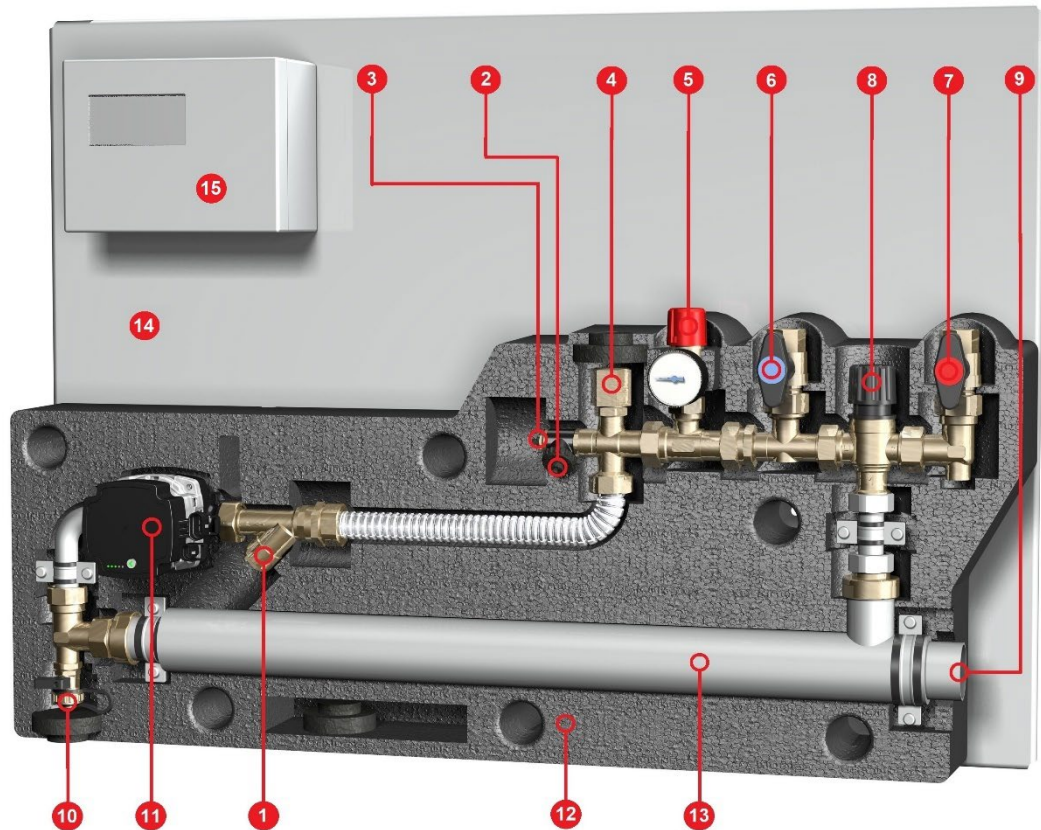

- 1 Mud flap
- 2 Filling valve
- 3 Vent valve
- 4 Connection for possible expansion tank (1" internal thread, flat sealing)
- 5 Pressure relief valve
- 6 Return flow shutoff & OXYban hose connection
- 7 Flow shutoff & OXYban hose connection
- 8 Thermostatic valve 50-75°C
- 9 1½" threaded connection for screw-in heater
- 10 Drain cock
- 11 Circulation pump
- 12 Insulation housing
- 13 Instantaneous water heater **ASKOFLOW**
- 14 Console rear wall
- 15 Electrical junction box prepared for **ASKOHEAT+** screw-in heater

Components

Pump	Type:	Grundfos UPM3 Auto 15-70
	Power range:	min. 5W (0.07A) max. 52W (0.52A) at 1.0MPa maximal pumping height 7m
	Connection:	230V ~ 50/60Hz

Pump capacity

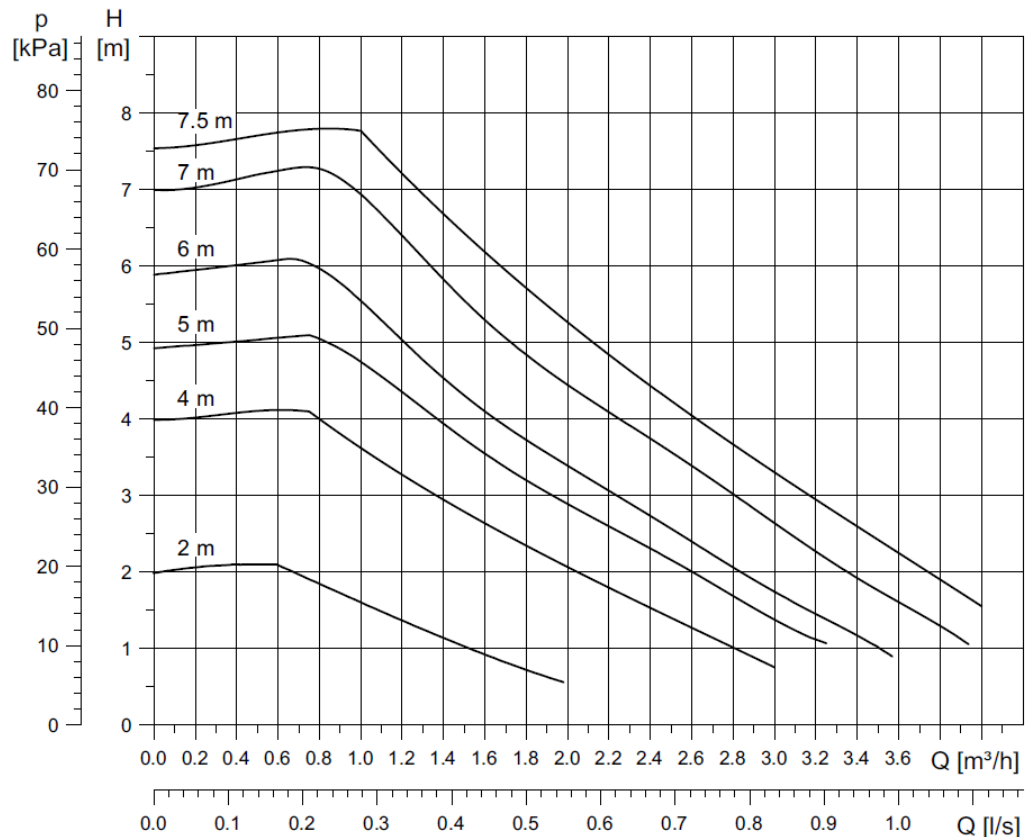

Pressure gauge:	Pressure range:	0-4 bar
	Gauge:	Ø 50mm

Pressure relief valve:	Type:	DUCO safety valve DN25
	Reaction pressure:	3 bar (permanently set)
	Max. heat output:	50kW
	Temperature:	-10°C up to +120°C
	Medium:	Water and water glycol mixture up to 50%
	Material:	Brass CW614N
	Standard:	NEN-EN-ISO 4126-1

Thermostatic valve:	Type:	tubra®-therm 507.19.00
	Adjustment range:	+50°C up to +75°C
	Flow factor:	1.9m³/h
	Material:	Brass CuZn39Pb3 (2.0401)

Ball valve:	Connection:	3/4" internal thread
	Material:	Brass

Filling valve:	Connection:	3/4" external thread
	Material:	Brass

Connection-expansion vessel:	Connection:	3/4" external thread
	Material:	Brass

Vent cock:	Connection:	3/4" external thread
-------------------	-------------	----------------------

Dimensions

Dimensions of the wall console incl. screw-in heater

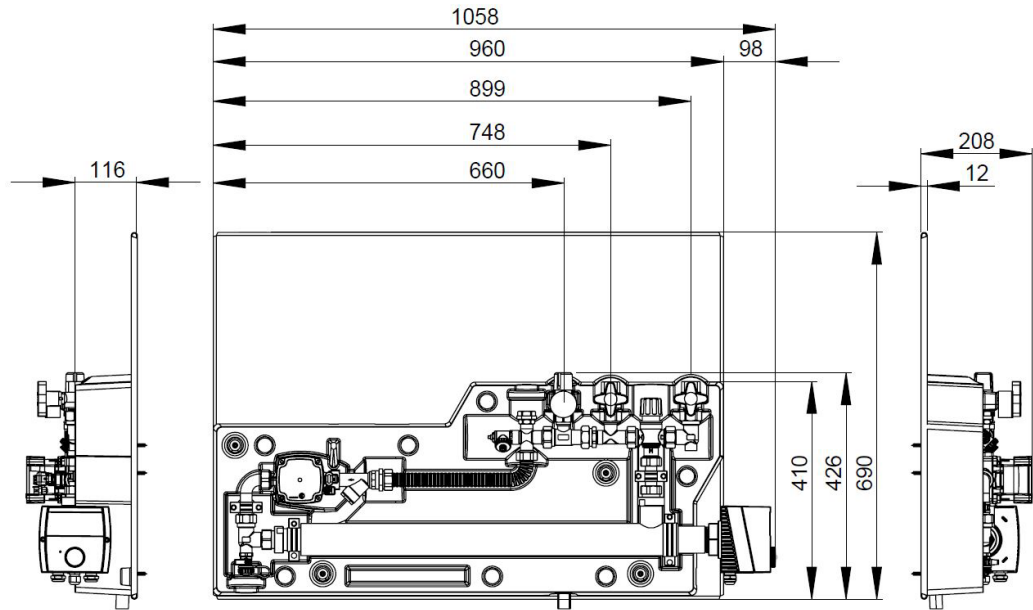

Description

The **ASKOWALL+** is designed for easy installation on any conventional buffer tank to provide the user with energy-efficient, smooth, high-temperature stratification. To this end **ASKOWALL+** can be connected directly to the relevant buffer tank.

On the **ASKOWALL+** the user sets the thermostatic valve (no. 8, see page 2) to the desired temperature, at which the valve should open, to fill the buffer tank with a minimum temperature. This can be chosen between 50 and 75°C.

Example: desired temperature is set at 60°C. The heating water in the **ASKOWALL+** circulates within the internal circuit until the water is heated to 60°C.

The thermostatic valve then opens and the hot water passes to the tank. This continues for as long as water at the desired temperature is available. Then, the thermostatic valve closes and the process begins again.

The **ASKOHEAT+** can heat the heating water up to 85°C and then the smart thermostat switches off.

Application possibilities

ASKOHEAT+ heating elements are available in a variety of power output levels.

These are available for single (230V~) and three-phase operation (400V 3~)

The **ASKOHEAT+** can be controlled via LAN, with Modbus-TCP / -RTU.

Which of these screw-in heaters should be used depends on the surplus power output of your PV system.

The **ASKOWALL+** can also be used as direct heating.

Application examples

Hygienic tank with integrated solar heat exchanger

The **ASKOWALL+** is designed for easy installation on a **hygienic tank with integrated solar heat exchanger**.

To this end, the **ASKOWALL+** can be connected directly to the solar heat exchanger loop. This requires the customer to connect a solar expansion tank to connection no. 4 (see page 2) (size must be dimensioned and supplied by the technician on the basis of internal volume).

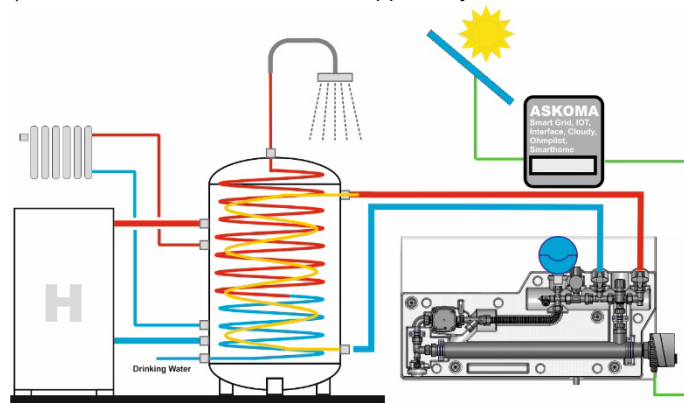

Hygienic tank without integrated solar heat exchanger

The **ASKOWALL+** is designed for easy, direct installation on a **hygienic tank** to provide the user with energy-efficient, smooth, high-temperature stratification.

ASKOHEAT+ heating elements are available in many performance sizes.

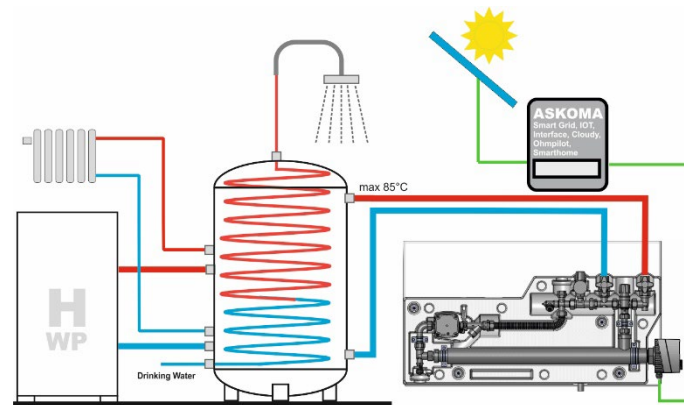

Buffer tank

The **ASKOWALL+** is designed for easy, direct installation on a **buffer tank** to provide the user with energy-efficient, smooth, high-temperature stratification.

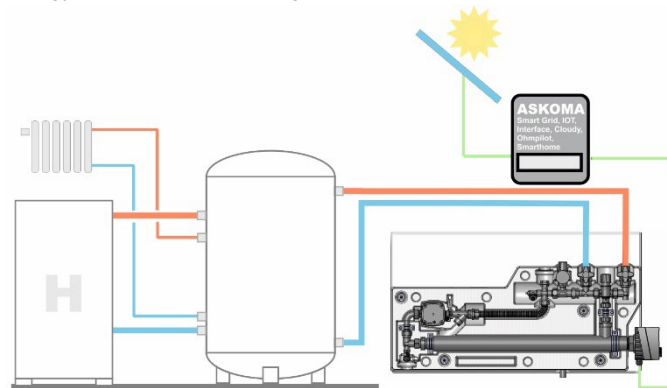

Mounting

Installation of the wall console

The **ASKOWALL+** can be attached to the wall using the four screws and dowels supplied.

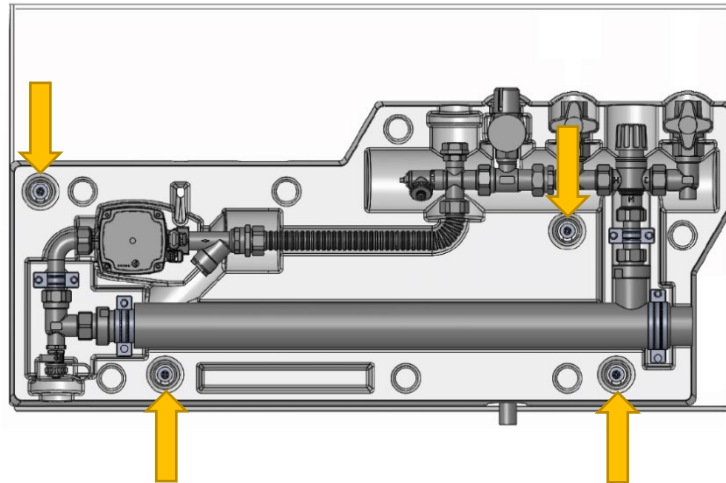

Position of the boring holes

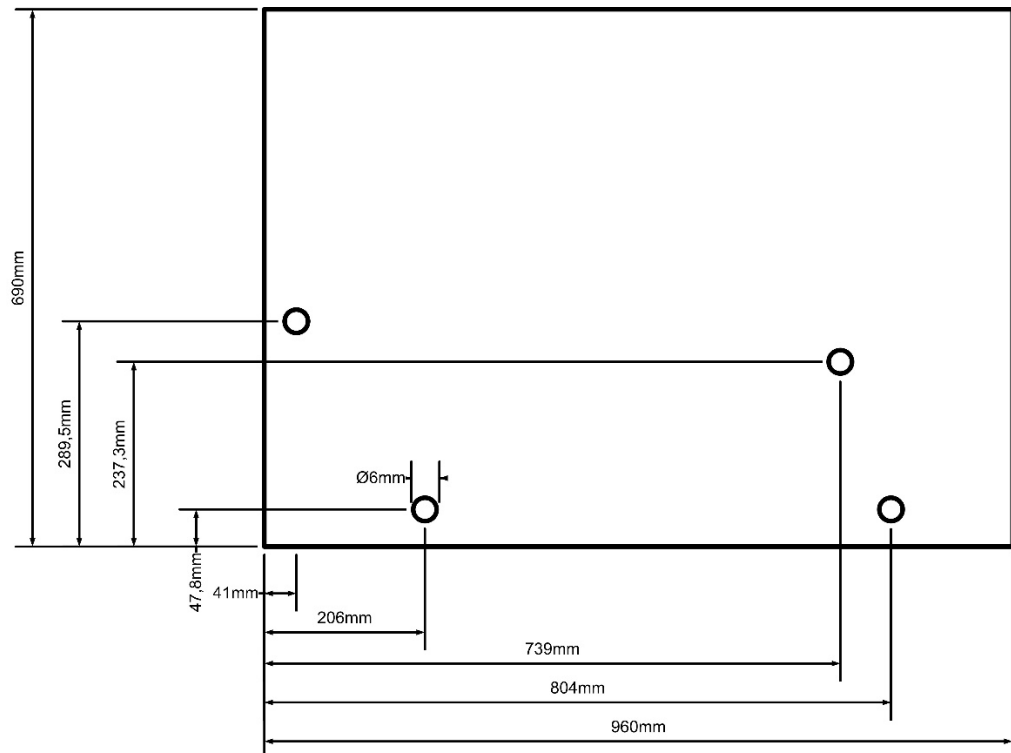

Fitting notes

The **ASKOWALL+** must be installed horizontally. Access must be guaranteed for inspection and maintenance. Uncovering the installation is not permitted. The **ASKOWALL+** must be installed in a dry and frost-free surrounding.

The screw-in heater must be covered entirely by the liquid. The circulation of the liquid shall not be inhibited.

Specific values

Pressure loss

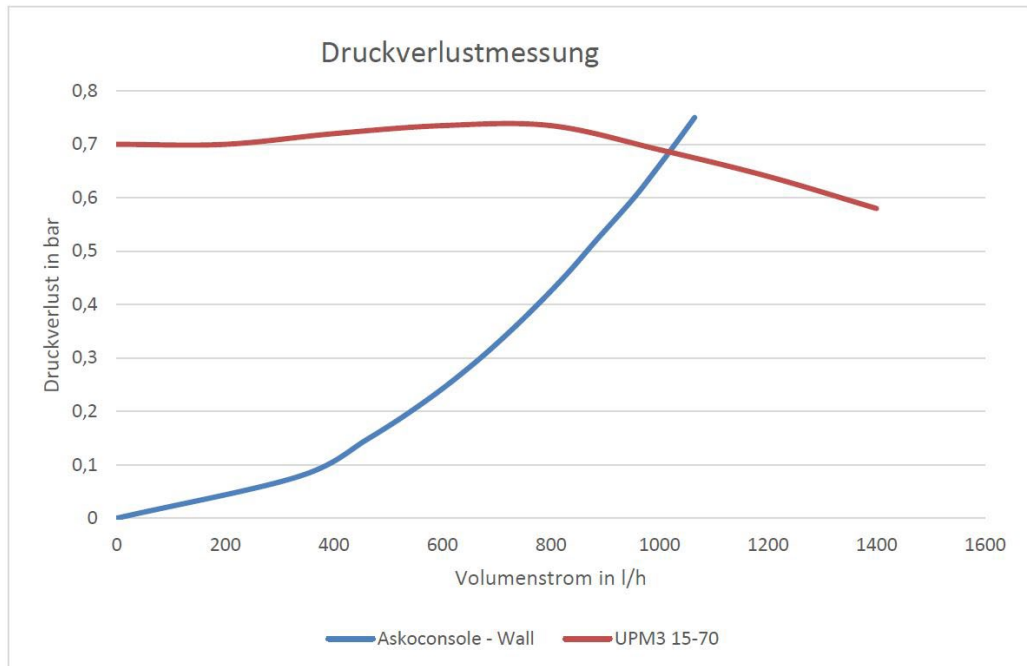

Electrical connections

Pre-wired connections of the ASKOWALL+

Connection cable for circulation pump

Connecting line between junction box (clamp X2) and the circulation pump

Connection cable temperature sensor

Connecting line between junction box (clamp X3) and the ASKOHEAT+

Connection cable heat pump request

Connecting line between junction box (clamp X4) and the ASKOHEAT+

Data cable energy manager

Connecting line between energy manager and the ASKOHEAT+

ASKOWALL+ connections to be set up by the customer

Supply line (energy manager and pump)

Power supply to the energy manager and the pump, connection box (clamp X1)

Supply line (ASKOHEAT+)

Power supply for the screw-in heater

Optional:

Connection of PV energy meter

Connection line between the energy meter of the PV system and the energy manager

Note !

The ASKOHEAT+ heating element and the energy manager require an Ethernet (LAN) connection to the local network.

This local network must be connected to the internet.

The ASKOHEAT+ and the energy manager must be able to establish a connection to the ASKOMA server for parameterization, registration and commissioning.

The data cannot be compared without a connection to the ASKOMA server. The ASKOHEAT+ heating element cannot be put into operation.

Anschlussbox to ASKOMALL+

