

## Wall console ready for connection

without screw-in heater, without Fronius Ohmpilot

### To maximise PV own power consumption

- for Fronius Ohmpilot continuously variable up to 9.0kW
- for high storage temperatures up to 85°C
- excellent legionella protection

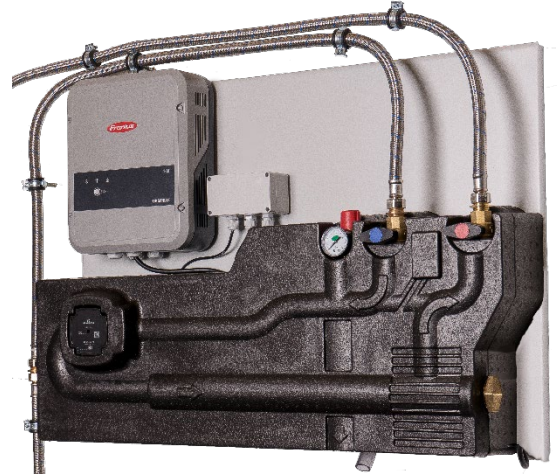

### Application

For external connection on heating buffer tank

1. For storage of PV energy as heat in heating water
2. As emergency heating for heating systems
3. For high storage temperatures for legionella protection (hygienic storage)
4. For existing buffer tanks without heating element access

### Features

This wall console can be retrofitted easily and individually and will be connected to the on-site buffer tank or integrated in the intake and outlet of the heating lines.

Increasing the storage temperature can contribute to legionella protection in a hygienic storage. A temperature between 50 and 75°C can be set manually on the thermostatic valve.

Thanks to the circulation pump in the **ASKOWALL-OP**, the water circulates until the set temperature is reached. As soon as this set temperature is reached, the valve opens and the hot medium is stratified in the storage tank. If the temperature in the **ASKOWALL-OP** falls below the set value due to cold water flowing in, the valve closes.

Continuously variable **ASKOHEAT-OP** screw-in heater with 1½" thread can be used up to a maximum immersion length of 750mm.

### Type summary

Type	Order no.	Additional text	Immersion length [EL]
<b>ASKOWALL-OP</b> for Fronius Ohmpilot	012-5500	1.0 kW up to 9.0 kW	up to max. 750mm
Connection hoses for <b>ASKOWALL-OP</b>	012-0130	1600mm length	

### Technical data

The following indications are valid for the above listed standard types. Due to the function, other types might show different data.

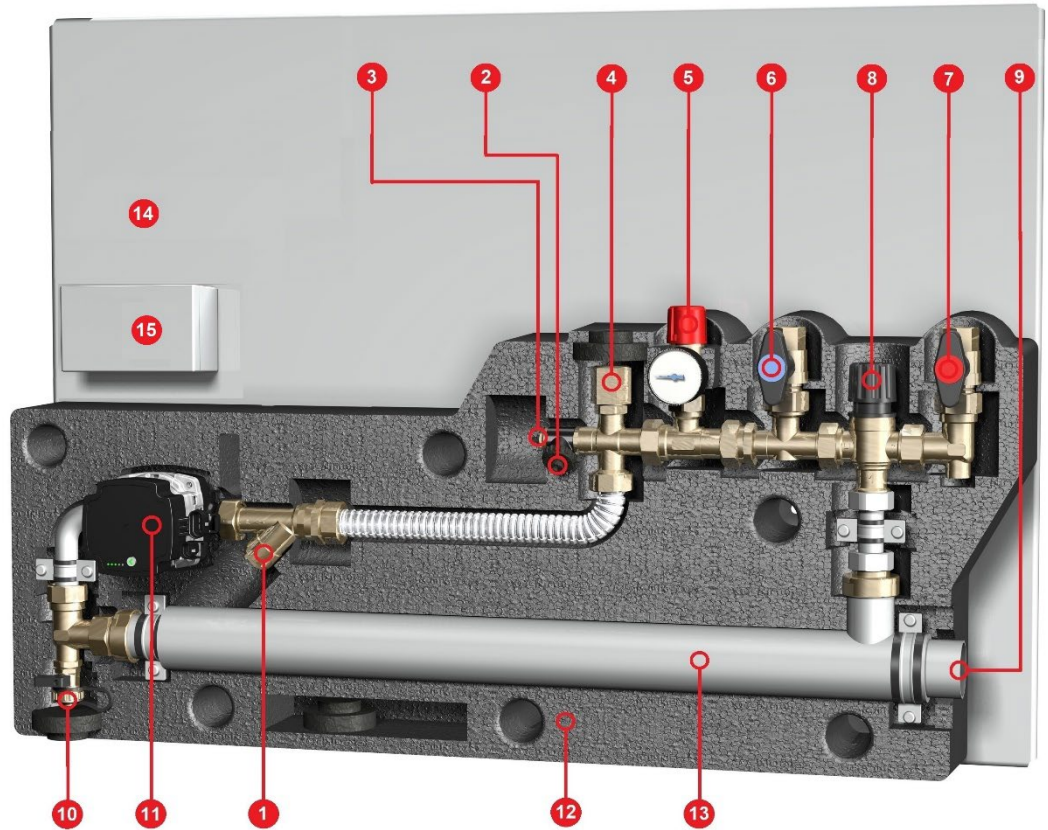

- 1 Mud flap
- 2 Filling valve
- 3 Vent valve
- 4 Connection for possible expansion tank (1" internal thread, flat sealing)
- 5 Pressure relief valve
- 6 Return flow shutoff & OXYban hose connection
- 7 Flow shutoff & OXYban hose connection
- 8 Thermostatic valve 50-75°C
- 9 1½" threaded connection for screw-in heater
- 10 Drain cock
- 11 Circulation pump
- 12 Insulation housing
- 13 Instantaneous water heater **ASKOFLOW**
- 14 Console rear wall
- 15 Electrical junction box prepared for connection of circulation pump, controlled by Fronius Ohmpilot

## Components

**Pump**                      Type:                      Grundfos UPM3 Auto 15-70  
                                  Power range:            min. 5W (0.07A)  
                                                                     max. 52W (0.52A) at 1.0 MPa  
                                                                     maximal pump height 7m  
                                  Connection:            230V ~ 50/60Hz

### Pump capacity

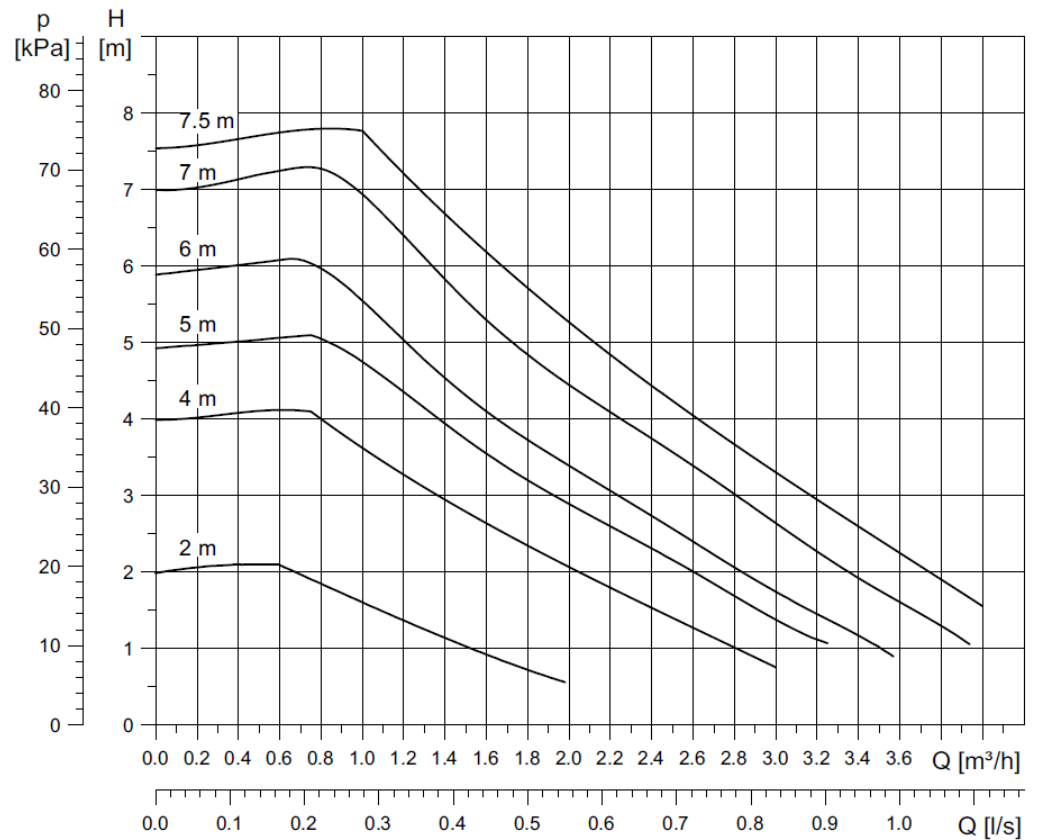

**Pressure gauge:**                      Pressure range:            0-4 bar  
                                  Gauge:                      Ø 50mm

**Pressure relief valve:**            Type:                      DUCO safety valve DN25  
                                  Reaction pressure:       3 bar (permanently set)  
                                  Max. heat output:       50kW  
                                  Temperature:            -10°C up to +120°C  
                                  Medium:                    Water and water glycol mixture up to 50%  
                                  Material:                    Brass CW614N  
                                  Standard:                    NEN-EN-ISO 4126-1

**Thermostatic valve:**                Type:                      tubra®-therm 507.19.00  
                                  Adjustment range:       +50°C up to +75°C  
                                  Flow factor:               1.9 m³/h  
                                  Material:                    Brass CuZn39Pb3 (2.0401)

**Ball valve:**                            Connection:                3/4" internal thread  
                                  Material:                    Brass

**Filling valve:**                        Connection:                3/4" external thread  
                                  Material:                    Brass

**Connection - expansion vessel:**    Connection:                3/4" external thread  
                                  Material:                    Brass

**Vent cock:**                            Connection:                3/4" external thread

## Dimensions

### Dimensions of the wall console incl. screw-in heater

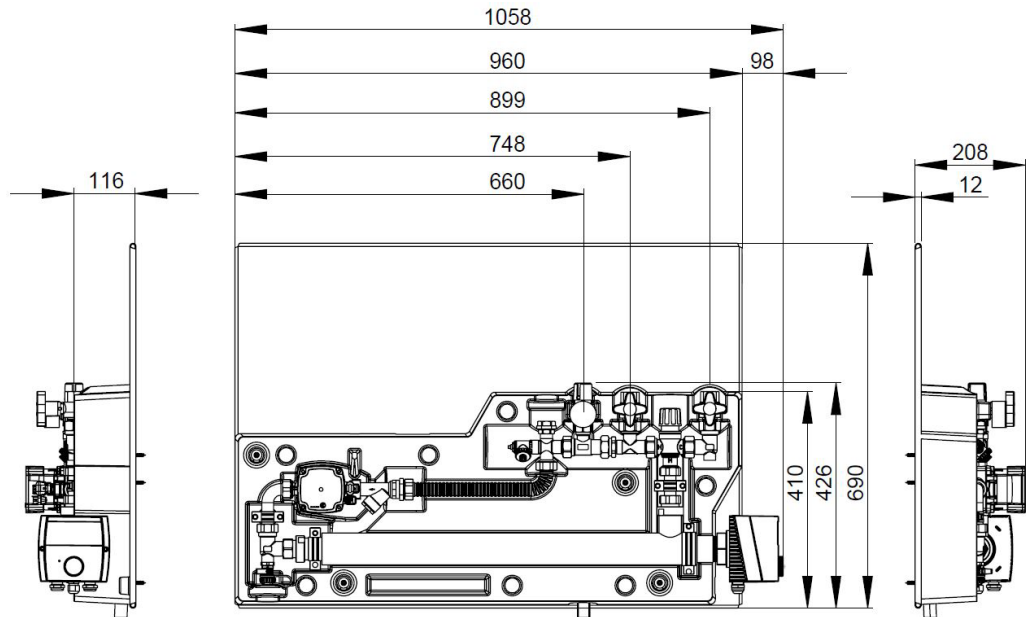

## Description

The **ASKOWALL-OP** is designed for easy installation on any conventional buffer tank to provide the user with energy-efficient, smooth, high-temperature stratification.

To this end **ASKOWALL-OP** can be connected directly to the relevant buffer tank.

On the **ASKOWALL-OP** the user sets the thermostatic valve (no. 8, see page 2) to the desired temperature, at which the valve should open, to fill the buffer tank with a minimum temperature. This can be chosen between 50 and 75°C.

Example: desired temperature is set at 60°C. The heating water in the **ASKOWALL-OP** circulates within the internal circuit until the water is heated to 60°C.

The thermostatic valve then opens and the hot water passes to the tank. This continues for as long as water at the desired temperature is available. Then, the thermostatic valve closes and the process begins again.

The **ASKOHEAT-OP** can heat the heating water up to 85°C and then the smart thermostat switches off.

## Application possibilities

**ASKOHEAT-OP** heating elements are available in a variety of power output levels, with the total heating output from 1.0 to 9.0kW.

Which of these screw-in heaters should be used depends on the surplus power output of your PV system and your energy management system.

It sounds complicated, but it isn't – we are happy to provide you with information about which **ASKOHEAT-OP** heating element you require.

The **ASKOWALL-OP** can also be used as direct heating.

## Application examples

### Hygienic tank with integrated solar heat exchanger

The **ASKOWALL-OP** is designed for easy installation on a **hygienic tank with integrated solar heat exchanger**.

To this end, the **ASKOWALL-OP** can be connected directly to the solar heat exchanger loop. This requires the customer to connect a solar expansion tank to connection no. 4 (see page 2) (size must be dimensioned and supplied by the technician on the basis of internal volume).

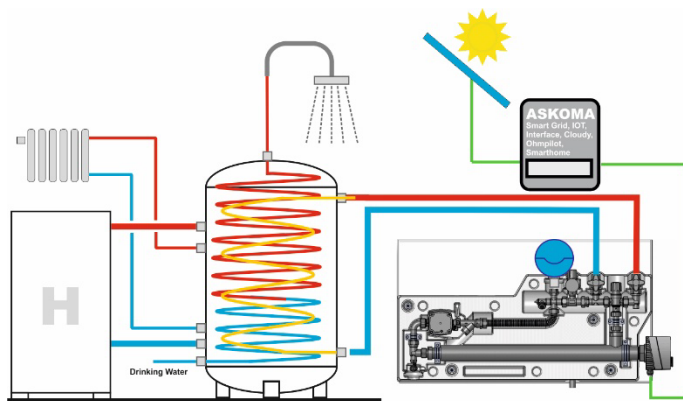

### Hygienic tank without integrated solar heat exchanger

The **ASKOWALL-OP** is designed for easy, direct installation on a **hygienic tank** to provide the user with energy-efficient, smooth, high-temperature stratification.

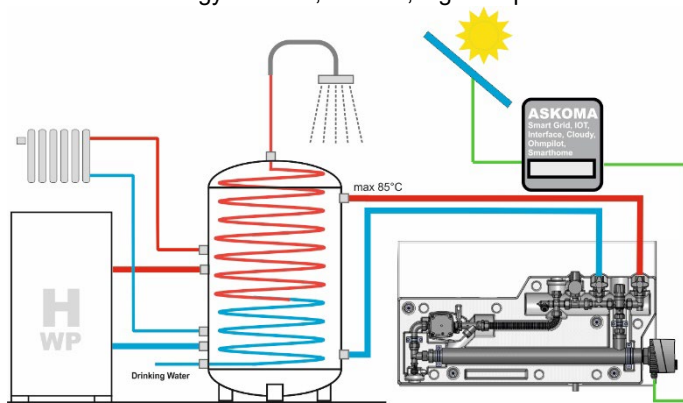

### Buffer tank

The **ASKOWALL-OP** is designed for easy, direct installation on a **buffer tank** to provide the user with energy-efficient, smooth, high-temperature stratification.

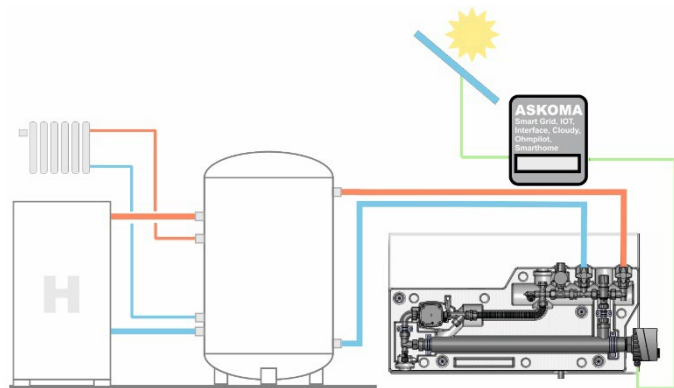

## Mounting

### Installation of the wall console

The **ASKOWALL-OP** can be attached to the wall using the four screws and dowels supplied

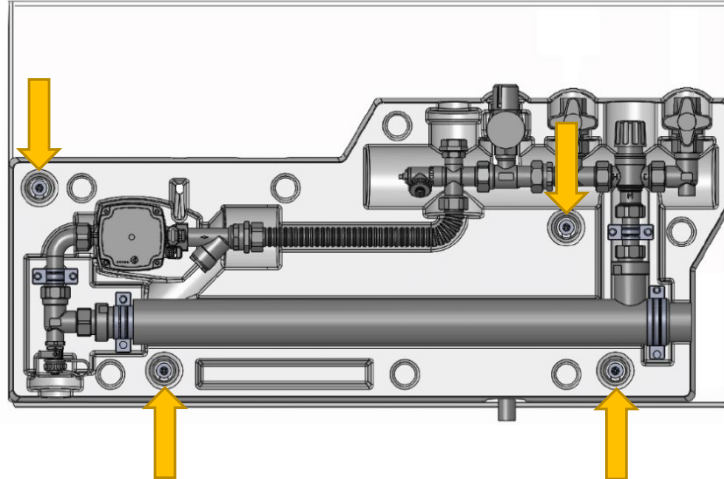

### Position of the boring holes

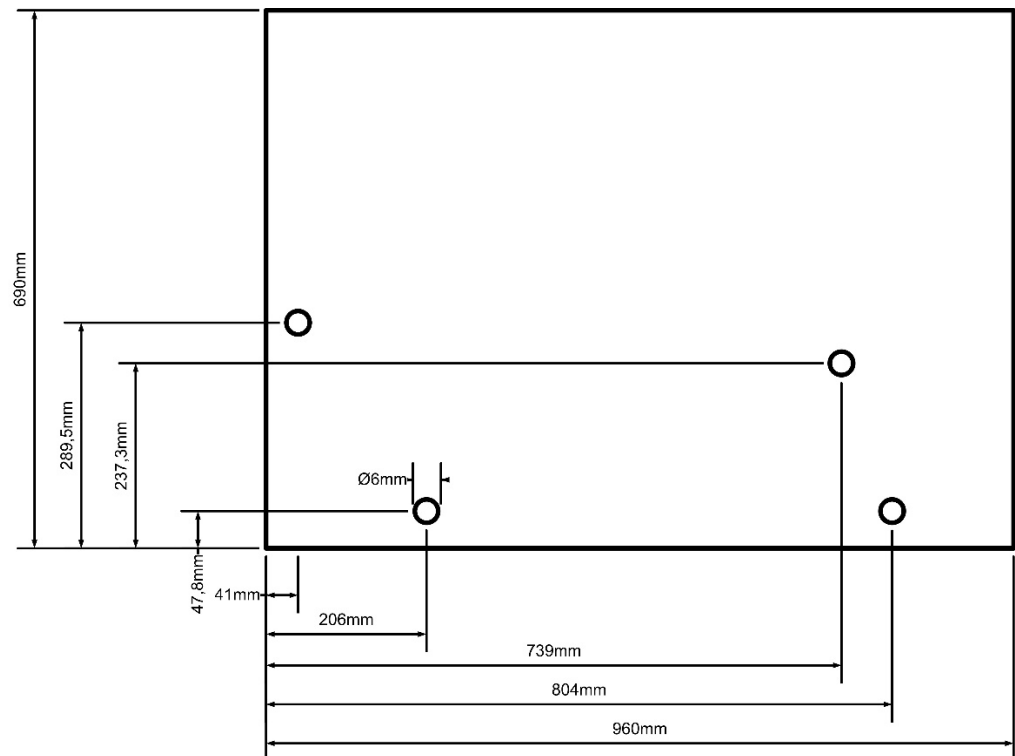

## Fitting notes

The **ASKOWALL-OP** must be installed horizontally. Access must be guaranteed for inspection and maintenance. Uncovering the installation is not permitted. The **ASKOWALL-OP** must be installed in a dry and frost-free surrounding.

The screw-in heater must be covered entirely by the liquid. The circulation of the liquid shall not be inhibited

## Specific values

### Pressure loss

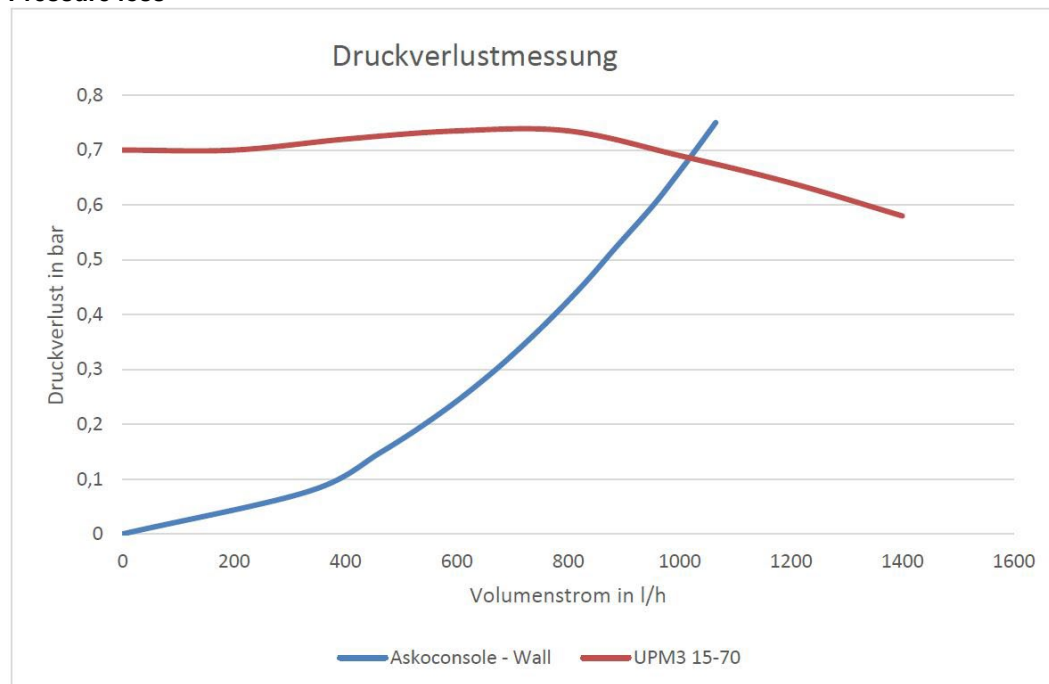

## Electrical connections

### ASKOWALL-OP connections to be set up by the customer

#### Connection cable screw-in heater (heating circuit)

Connecting line between Fronius Ohmpilot (clamp 2/3 and 4) and screw-in heater  
Suggestion ASKOMA: 5x2.5mm<sup>2</sup>

#### Power supply circulation pump

The supply line of the circulation pump in the junction box (clamp X1)  
Suggestion ASKOMA: 3x1.5mm<sup>2</sup>

#### Control of the circulation pump

Connection cable between junction box (clamp X3) and Fronius Ohmpilot  
Suggestion ASKOMA: cross section 1.5mm<sup>2</sup>

# Connection diagram

## Junction box to ASKOWALL for Fronius Ohmpilot

